

P3I_RGB / QUADRO

4-Channel PCI Frame Grabber for RGB and Monochrome Analog Cameras

- PCI performance
- Quadro acquisition RGB inputs

III Main Features

- Frame grabber for 4 simultaneous monochrome channels or one RGB image
- Digitizes four parallel, separate images from synchronized cameras; a separate version for four non-synchronized cameras is available.
- Parallel acquisition into RAM and graphics
- Trigger inputs
- On-board sync generator
- Restart cameras supported
- Real-time acquisition of images or image sequences directly into main memory
- Image memory formats include RGB and monochrome with 32 or 8 bits/pixel
- PCI 2.2 compliant

III Technical Details

The p3i_RGB is intended for applications where up to four parallel channels are digitized, such as RGB data with an additional alpha channel or four monochrome synchronous cameras are used ("quadro", analogous to stereo). It permits connection of RGB cameras.

In quadro mode, the four images are stored in separate memory regions as separate monochrome images. The up to four cameras (same type) must be synchronized for this operating mode and must be used with the same number of pixels. An on-board sync generator with four separate 75-ohm outputs makes synchronization easy.

The region of interest, i.e. the part of the video information that is acquired, can be defined on a pixel basis for all 4 video inputs with the same values - not always the full frame has to be acquired.

Pixel Clock Generation

The clock used to digitize all four channels is generated either by an on-board PLL, synchronized to the horizontal camera sync with a pixel jitter of ≤ 7 ns or it is taken directly from the pixel clock input for camera-synchronous digitization.

Analog-Digital Converter / Multiplexer

The four independent A/D converters digitize data each with 8 bits resolution at rates between 5 and 32 MHz. Each ADC can sample data from 4 input ports.

Trigger Processing

The p3i_RGB has opto-isolated trigger inputs with additional outputs used to trigger cameras. Strobe lights can also be triggered by the trigger inputs.

DMA Controller

In the last step image data is transmitted by DMA directly into main memory or into the graphics card.

This DMA controller consists actually of four independent controllers, capable of transferring four video data streams into four independent memory regions.

Bus	PCI / Rev 2.2
width	32 bits
speed	33 MHz
bandwidth	>80 MHz (typ.)

Frame Grabber Basic Tools

Drivers for Windows come in the form of a DLL for Windows 98/ME/NT/2000/XP. Setup of the ADC, offset/gain, region-of-interest adjustment, camera selection, scaling, color format conversion, and camera setup files are supported.

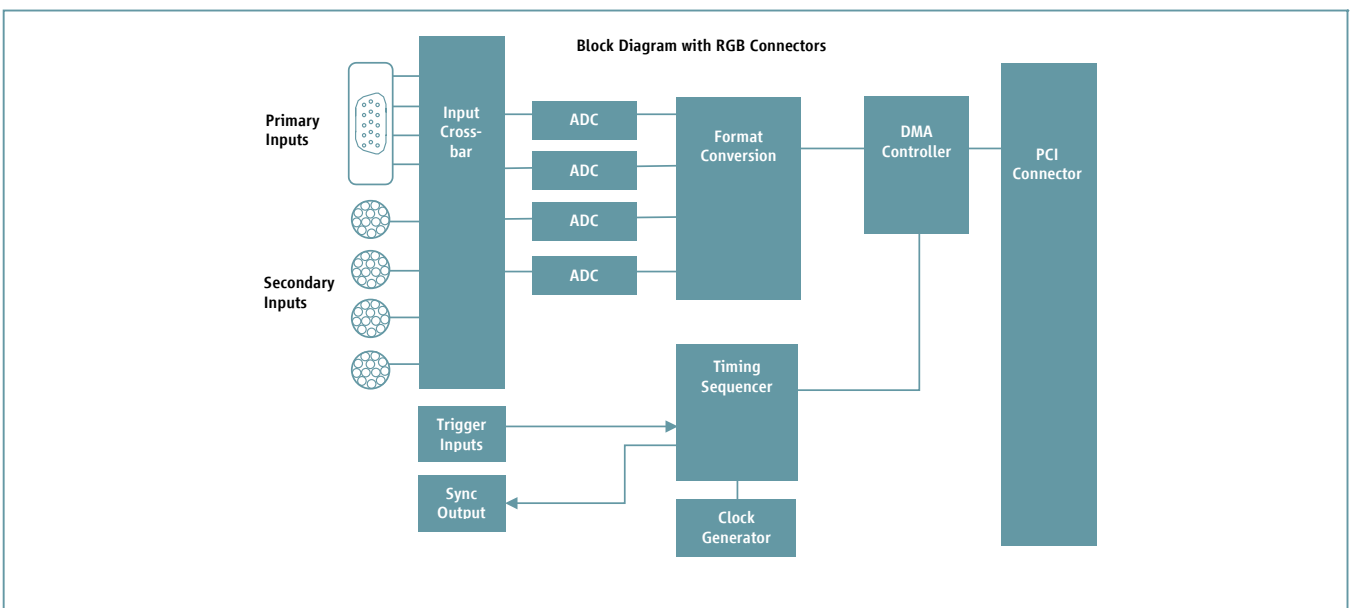

Permanent (live), single-shot, and double-buffered acquisition of images can be requested and the status of the acquisition (active / finished) can be inquired.

Memory allocation for image buffers is also handled by the DLL at runtime; frame buffers appear in linear memory for easy addressing
A setup program supports test and configuration of the board under Windows
Display routines using the DirectDraw standard are supplied in source. This software level is intended for users who already have their own software support available, such as image processing libraries, or wish to create application programs by themselves.

Frame Grabber Basic Tools is available for Windows 98/ME/NT/2000/XP and for Linux. For the real-time operating systems VxWorks and OS-9 there is a reduced version (available on request), where parameters are set in configuration files only and where no display routines are included.

Pixel Packing Modes

To support different cameras and applications, there are several modes of storing pixel data in memory:

Mode	Memory storage
Mono	Four individual monochrome images
RGB24	One 24-bit RGB channel, packed in double words.
RGB32	One 24-bit RGB channel stored as double word, unused high-order byte is zero
RGB32_3	One 24-bit RGB channel stored as double word. High-order byte is monochrome channel 3
RGB555	One 15-bit RGB channel stored as Word, the MSB is Zero. One additional monochrome channel
RGB565	One 16-bit RGB channel stored as Word. One additional monochrome channel
RGB555M	One monochrome channel stored as 15-bit RGB. Additional two monochrome channels
RGB565M	One monochrome channel, stored as 16-bit RGB. Additional two monochrome channels

15- and 16-bit RGB and monochrome modes are not intended for processing, but are useful for direct transfer to a graphics board that runs in the corresponding mode (Hicolor e.g.). In that case the additional monochrome channel - which can be programmed to contain the same video data - can also be stored in memory for efficient processing.

High-Level Software

Support for several 3rd-party imaging tools is available under Windows:

AdOculus (The Imaging Source) is a tool for visual image processing algorithm development. All of the basic algorithms are supplied in source form for easy modification and expansion.

Heurisko (Aeon Verlag+Studio) is a tool for development of highly optimized imaging algorithms using a C-like scripting language.

Halcon (MVTec) is a very complete tool set with an integrated scripting language.

The freeware imaging library IPL98 has been tested to work; there is a demo source, showing how to use it.

Cameras Supported

Cameras with reset/restart features are supported, as well as pixel clock input to the frame grabber for sub-pixel accuracy.

Camera	Features supported
Generic RGB	Free-running
Generic CCI625	Free-running
Sony XC-55	Full frame, Interlaced, Restart, Long time exp., E-Donpisha II
Sony 003 P	RGB Restart
Sony XC-ST50CE	t.b.d.
Sony XC-ST70CE	t.b.d., Full frame, Donpisha
Sony XC 8500	Dual, Restart
Teli 3910	Full frame, fixed, RTS pulsed Megapixel
JAI M-10 RS	Dual, Full frame, Restart
JAI M50	Restart
JAI M70	RGB, Full frame, Restart
JAI M1	t.b.d.

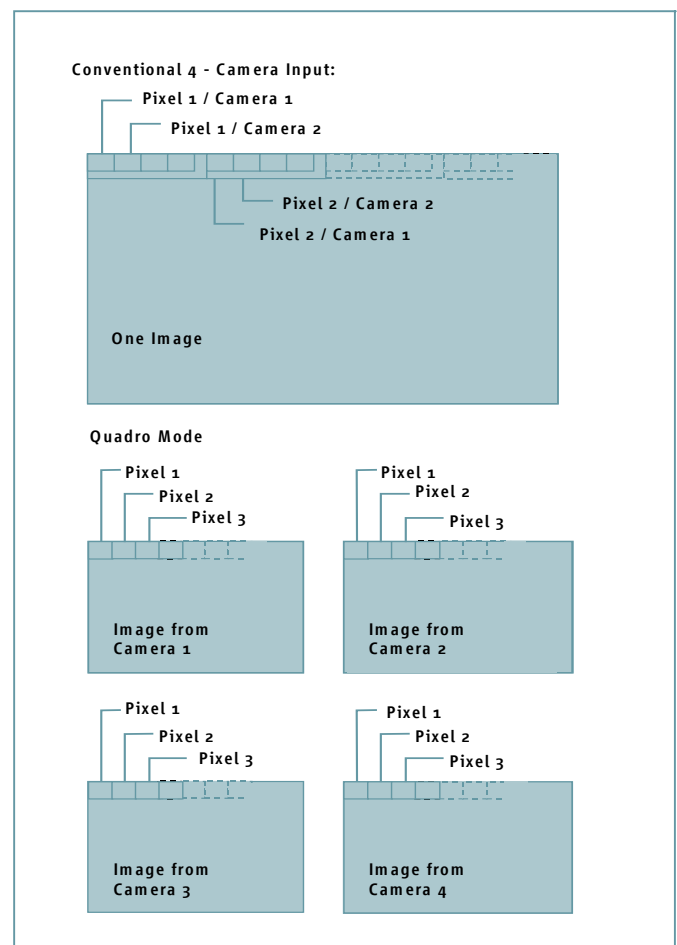

ELTEC Elektronik AG

Galileo-Galilei-Strasse 11
55129 Mainz
PO Box 10 03 64
55134 Mainz

Fon +49 6131 918 100
Fax +49 6131 918 195
Email info@eltec.com
www eltec.com

ELTEC International SARL

1, Allée des Garays
91872 Palaiseau
France

Fon +33 1 64 47 18 77
Fax +33 1 64 47 09 33
Email info.fr@eltec-france.fr
www eltec-france.fr

American ELTEC, Inc.

2401 Windjammer Way
Las Vegas, Nevada 89107
USA

Fon +1 702 878 40 85
Fax +1 702 878 47 35
Email info.us@eltec.com
www americaneltec.com

ELTEC International PLC

Unit 32, Stratford Office Village
Wolverton Mill
Milton Keynes MK12 5NS
United Kingdom

Fon +44 1908 32 00 55
Fax +44 1908 31 01 07
Email info.uk@eltec.com
www eltec.com

III Specifications

ADC

→ 8-bit, 32 MHz, 4 channels parallel.

Connectors (RGB Version)

- 2* 3-row, 15-pin D-Sub female: Video inputs 1..4 (0.7 Vpp nom.) each
- 2 * 12V-Camera supplies
- 4 * 75-Ohm sync / restart outputs
- 2 * Pixel clock input (TTL, 75 Ohm)
- 2 * Trigger input (TTL)

Connectors (Quadro Version)

- 4 * 12-pin Hirose + 1 * DB 15 (for triggers)
- 4 * 12V-Camera supplies
- 12 * 75-Ohm sync / restart outputs
- 4 * Pixel clock input (TTL, 75 Ohm)
- 4 * Trigger input (TTL)

Environmental Conditions

- Storage Temperature: -20 °C - 70 °C
- Operating Temperature: 0 °C - 45 °C (2 m/s forced air cooling)
- Maximum Operating Humidity: 85 % relative

Power Requirements

- 0.55A max., 0.5A typ. at + 5 VDC ± 5 %
- 0.2A max., 0.18A typ. at + 12 VDC ± 5 %
- 3A max. total, 12V for camera supply
- 1.1A max. for each of the 4 camera supply outputs

PCI bus Requirements

- PCI 2.2 compliant
- Graphics board should be connected to AGP, rather than to PCI
- Maximum bus load generated by other boards: <20 MB/s for 100µs max.

MTBF

- T.b.d. hrs (computed after MIL-HDBK-217E)

Documentation

- Free Internet

Please contact your local sales office for detailed information.

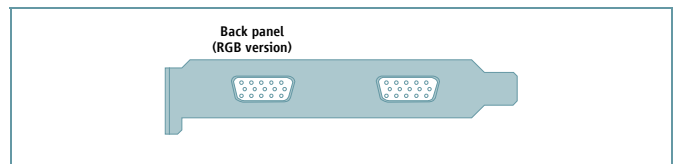
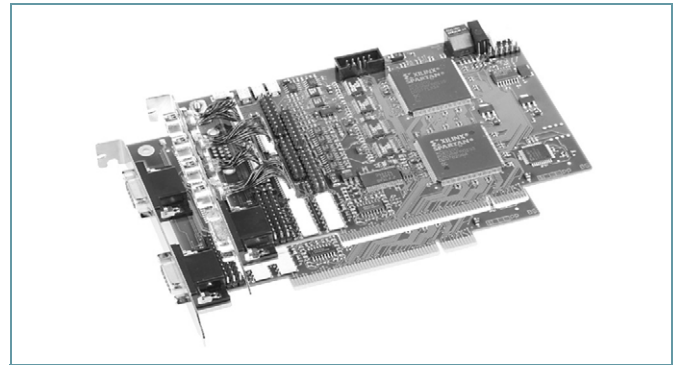

DB15		Hirose	
Pin	Signal	Pin	Signal
1	R analog	1	Gnd
2	G analog	2	+12V
3	B analog	3	Gnd
4	A analog	4	Video
5	Gnd	5	Gnd
6	Gnd	6	GPout
7	Gnd	7	GPout1/ExtClk
8	Gnd	8	Gnd
9	Trig+	9	GPout2/ExtClk
10	Gnd	10	Gnd/GPin
11	Trig-	11	+12V/GPout
12	Clock	12	Gnd
13	GPout0		
14	GPout0		
15	+12V		

Note: Depends on jumper settings

PC_EYE 2 Compatibility

The p3i_RGB is the successor of the PC_EYE2 frame grabber board in its RGB version -it is software-compatible to the PC_EYE2 where applicable.